

Measure ultraviolet radiation

The ultraviolet meter measures and displays instantaneous readings of the ultraviolet radiation between 250 and 400 nanometers (nm) in $\mu\text{mol m}^{-2} \text{s}^{-1}$ (micromoles of photons per square meter per second) or Watts. The self-cleaning dome-shaped head of the MU-200 prevents water accumulation. The sensor head is potted solid to prevent internal condensation in humid environments.

Although the relative wavelengths of UV radiation differ among sunlight and electric lights, our measurements indicate that this sensor provides a close estimate of the UV radiation coming from electric lamps. This meter is particularly useful for determining the UV filtering capacity of the transparent plastic and glass barriers that are commonly used below electric lamps.

Each meter can store up to 99 manually recorded measurements. In automatic mode, measurements are made every 30 seconds and averages are stored every 30 minutes. Daily totals are also calculated and the past 99 days are recorded. The AC-100 communication cable must be purchased to download data to a PC.

Viewable on meter display & downloadable to a PC:

- (SMPL) 99 Sample Measurements
- (LOG) 99 Log Measurements

Downloadable only:

- (LOG) 99 Daily Total Measurements



Related Products



AL-100

A plate used to keep meters with separate sensor level. (MQ-200)



AL-210

Leveling plate and mounting base for meters with integral sensor.



AC-100

Communication cable is required for data download to a computer.

Specifications

Memory

- 99 manually stored data points
- Automatically store 99 consecutive 30 minute averages

Range

- 0 - 199.9 $\mu\text{mol m}^{-2} \text{s}^{-1}$ (full UV in sunlight; 170 $\mu\text{mol m}^{-2} \text{s}^{-1}$)

Absolute Accuracy

- $\pm 10\%$

Input Power

- Standard 3 V coin cell battery

Mass

- MU-100: 150 g
- MU-200: 180 g

Long-Term Drift

- Less than 3% per year

Operating Environment

- 0 to 50 C
- Less than 90% non-condensing, relative humidity up to 30 C
- Less than 70% relative humidity from 30 to 50 C

Display

- 4.2 by 2.8 cm

Cable (MU-200 Series)

- 2 meters of twisted-pair wire
- Foil shield
- Santoprene jacket
- Longer cable lengths are available in multiples of 5 meters

Warranty

- 1 year against defects in materials and workmanship

Measurements

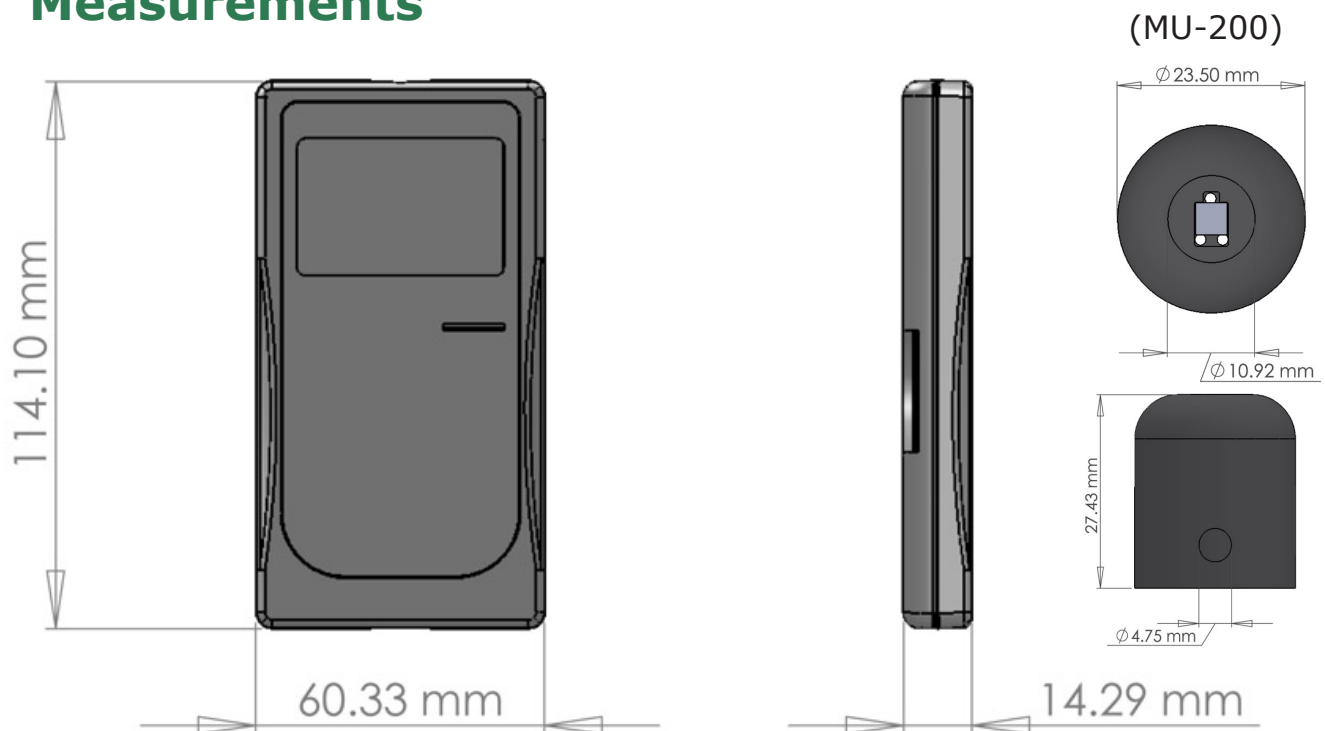

Scan to call us



www.apogeeinstruments.com



Scan for more information on MU meters