

Measure oxygen in air



This sensor is useful for monitoring soil respiration, aeration, and gaseous O₂ levels in laboratory studies.

The sensor is a galvanic cell sensor that has a lead anode, a gold cathode, an acid electrolyte, and a Teflon membrane. The current flow between the electrodes is proportional to the oxygen concentration being measured. An internal bridge resistor is used to provide a millivolt output. Being a galvanic cell type sensor, a small amount of oxygen is consumed in the reaction in order to produce the current flow and subsequent mV output. The oxygen consumption was measured to be 2.2 micromoles (μmol) O₂ per day when the O₂ concentration was 20.95% (3240 mmole) at 23 degrees Celsius.

The mV output responds to the partial pressure of oxygen in air. The standard units for partial pressure are kilopascals (kPa). However, gas sensors that respond to partial pressure are typically calibrated to read

out in mole fraction of the gas in air, which has units of moles of oxygen per mole of air. These units can be directly converted to percent O₂ in air or ppm O₂ in air.

Gas sensors read out in percent because this value does not change with temperature or pressure. The concentration of oxygen in our atmosphere is 20.95% and this value, to four significant digits, has not changed for decades. This means that we are surrounded by calibration gas for this sensor, provided you are not breathing on the sensor when it is being calibrated. Our exhaled breath is about 17% oxygen.

Related Product



The Barometric Pressure Sensor was developed for use with oxygen sensors, which are sensitive to barometric pressure fluctuations.

Specifications

Range

- 0 to 100% O₂

Accuracy

- < 0.02% O₂ drift per day

Repeatability

- ± 0.001% O₂ (10 ppm)

Operating Environment

- -20 to 60 C
- 0 to 100% relative humidity
- 60 to 140 kPa

Mass

- 175 g

Response Time

- SO-100 Series: 60 seconds
- SO-200 Series: 12 seconds

Output

- SO-100 Series: 50 mV
- SO-200 Series: 12 mV

Input Power

- 12 V power for heater
- 2.5 V excitation for thermistor

Diffusion Head (Accessory)

- 3.5 cm long by 3.5 cm diameter
- 125 mesh screen

Flow-Through Head (Accessory)

- 3.2 cm long by 3.2 cm diameter
- 1/8" barbed adapters for hose connections

Cable

- 5 meters of twisted-pair wire
- Foil shield
- Santoprene jacket
- Ending in pigtail leads
- Additional cable is available in multiples of 5 meters

Warranty

- 1 year against defects in materials and workmanship

Measurements

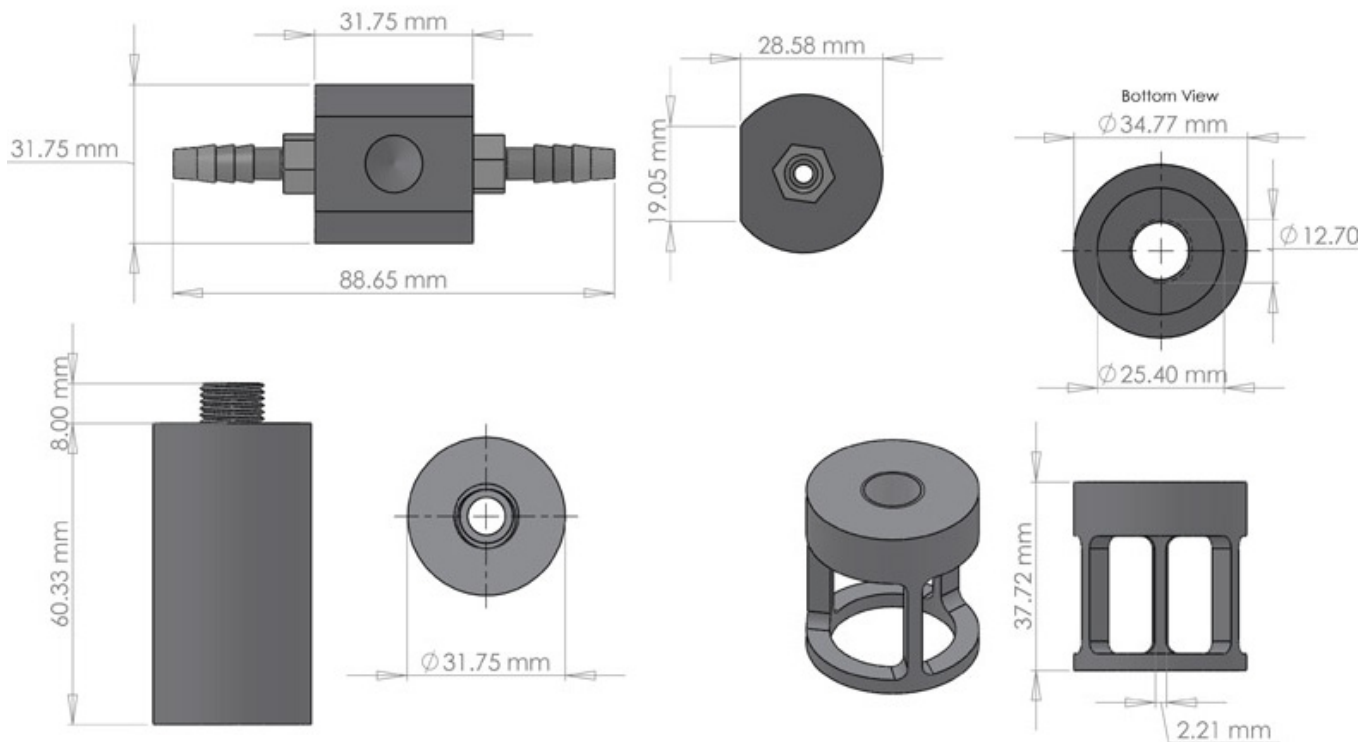

Scan to call us



www.apogeeinstruments.com



Scan for more information on SO sensors