

## Features

- SDI-12 output
- Customizable heater settings
- Precise start & stop precipitation timing measurements
- Sensitive capacitance circuit for accurate measurements



## Introduction

The heated precipitation detector measures precipitation frequency and length. The heating component allows it to detect solid precipitation such as sleet, snow, and hail in addition to liquid precipitation. By facilitating evaporation, it also increases the devices accuracy in measuring precipitation timing, even in short duration precipitation events. The heated precipitation detector can provide precise start and stop timing measurements.

The heated precipitation detector is built to minimize power consumption by using the minimum heater level required to maintain the desired temperature. The heater settings are customizable by the user to either increase the heater's performance or decrease the power consumption.

## Dimensions

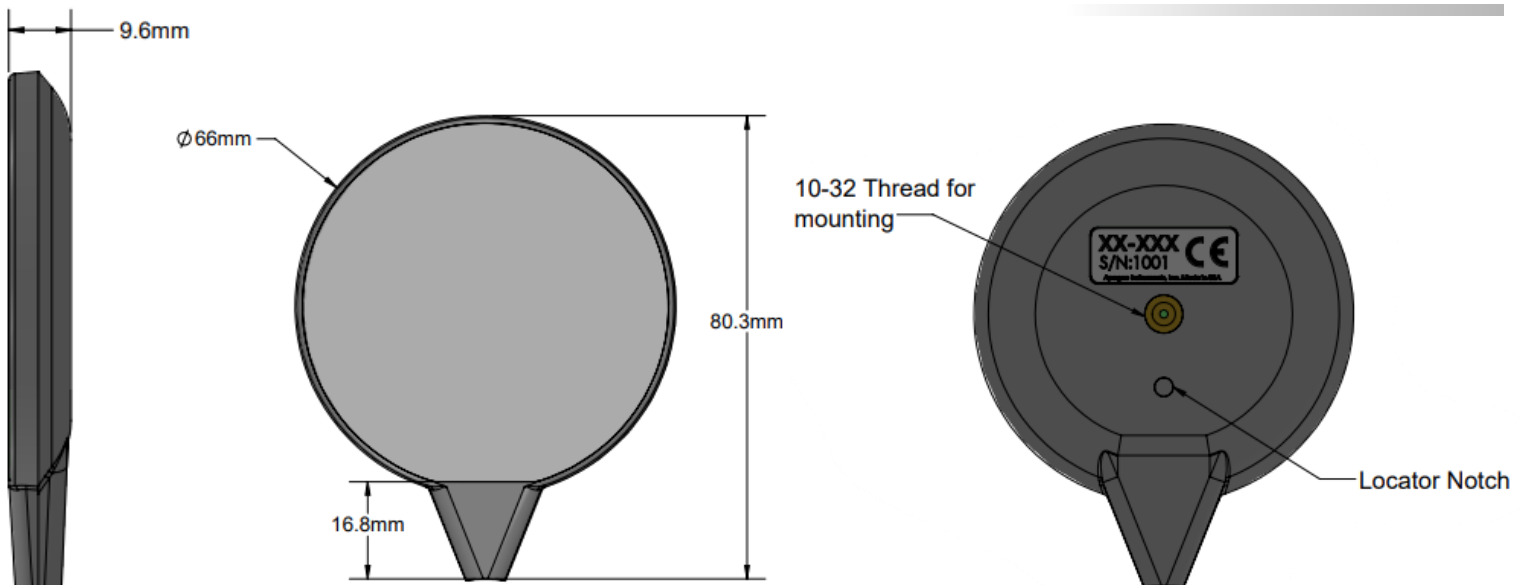

## Product Specifications

Input Voltage Requirement	12 V DC
Current Draw	16 to 393 mA
Operating Environment	-40 to 60 C, 0 to 100% relative humidity
Ingress Protection Rating	IP67
Mass	50 g
Dimensions	6.5 cm diameter, 9.6 mm width, 8.03 cm length
Output	SDI-12
Precipitation Type	Liquid, solid, mixed

## Current Draw

Heater PWM Duty Cycle [%]	Average Current [mA]	Max Current [mA]
0	20mA	20mA
10	60mA	400mA
20	100mA	400mA
25	120mA	400mA
30	140mA	400mA
40	180mA	400mA
50	220mA	400mA
60	250mA	400mA
70	290mA	400mA
75	310mA	400mA
80	330mA	400mA
90	360mA	400mA
100	400mA	400mA

The heater operates using a PWM signal. Instantaneous current draw of the heater switches between 0% and 100%. The power supply must be able to supply 100% current while using lesser percentages.

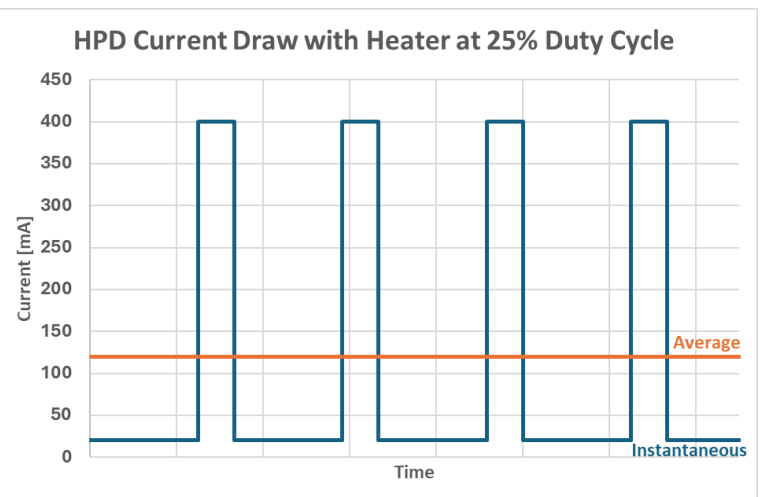
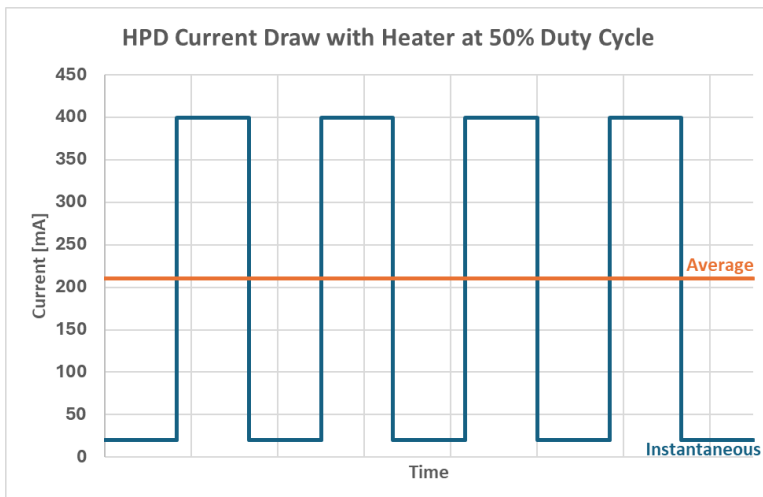

Rev: 11-Feb-2025