



EE08-SS



TS-220-SS

Product Specifications

TS-220-SS	
Difference Among Individual Replicate Shields	Less than 0.1 C
Aspiration Rate	6 m s ⁻¹ at full-speed; 3 m s ⁻¹ at half-speed
Fan Input Voltage Requirement	14.0 to 27.6 V DC
Fan Current Draw	80 mA at full-speed; 25 mA at half-speed
IP Rating	IP55
Dimensions	220 mm height, 270 mm diameter
Mass	840 g
Warranty	4 years against defects in materials and workmanship

EE08-SS	
Input Voltage	7 to 30 V DC
Current Draw	Less than 1.3 mA
Start-up Time	2 s
Housing	Polycarbonate, IP65
Filter	Stainless steel wire mesh, 30 micron pore size
Connector	M12, IP67
Dimensions	83 mm length, 12 mm diameter
Mass with 5 m Cable	270 g
Operating Environment	-40 to 80 C; 0 to 100 % relative humidity
Cable	M12 connector (IP67 rating) to interface to sensor housing, 5 m of four conductor, shielded, twisted-pair wire (10 m and 20 m cables also available), white TPR jacket (high water resistance, high UV stability, flexibility in cold conditions), pigtail lead wires
Warranty	1 year against defects in materials and workmanship

Temperature Measurement		Relative Humidity Measurement	
Sensor	PT1000 (Class A)	Sensor	Capacitance Chip
Measurement Range	-40 to 60 C	Measurement Range	0 to 100 %
Output Signal Range	0 to 2.5 V DC	Output Signal Range	0 to 2.5 V DC
Slope	0.04 C per mV	Slope	0.04 % per mV
Intercept	-40 C	Intercept	0.00 %
Accuracy at 20 C	± 0.2 C	Accuracy at 20 C	± 2 % from 0 to 90 %; ± 3 % from 90 to 100 %
Long-term Stability	Less than 0.1 C per year	Temperature Response	Less than -0.05 % per C
Time Constant	Less than 30 s	Long-term Stability	Less than 1 % per year
Accuracy Over Measurement Range	See graph above	Time Constant	Less than 30 s

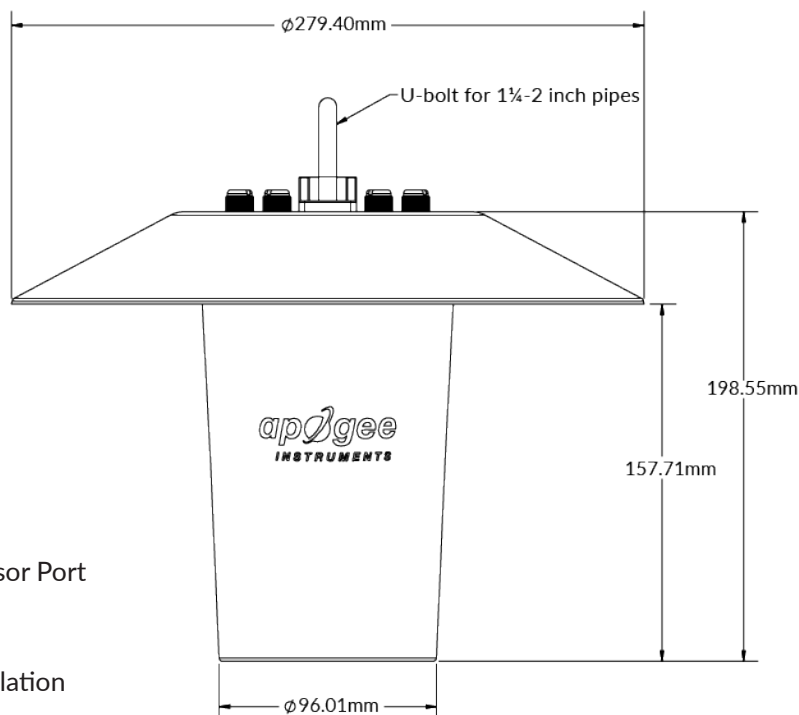
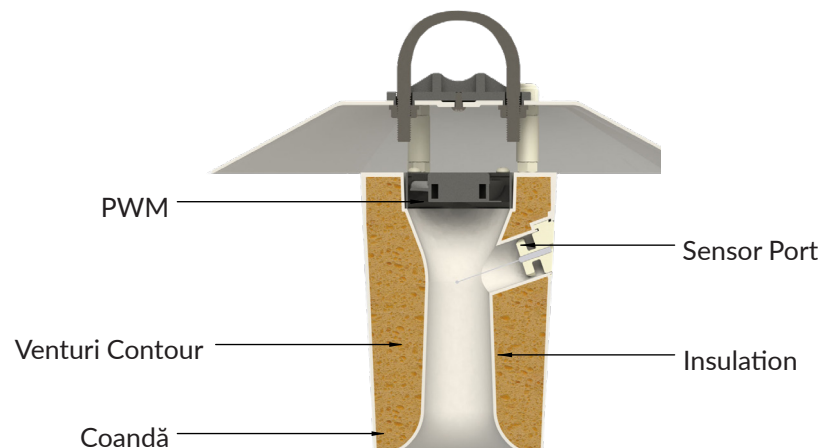
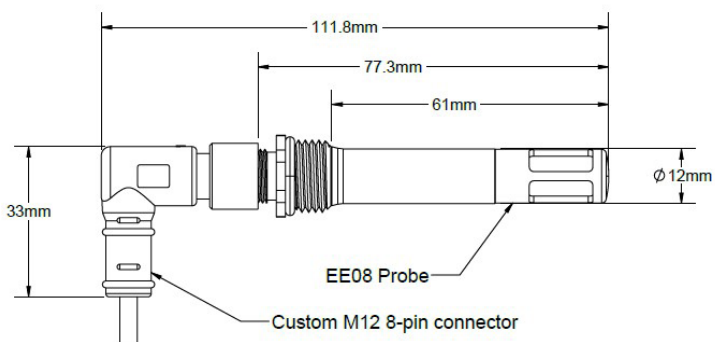

Features

TYPICAL APPLICATIONS

- Air temperature and humidity measurement in weather networks, often for weather forecasting
- The precise measurement of air temperature and humidity gradients above the land surface
- Climate change monitoring
- Meteorology and weather stations
- Hatcheries and incubators
- Climatic chambers and green houses



RUGGED, LOW POWER FAN

The fan has an ingress protection rating of IP55, which minimizes moisture and dust ingress. Fan speed and power can be further reduced when environmental conditions warrant. If the fan is continuously operated at full-speed, its lifetime is rated at 50,000 hours (5.7 years). The fan includes a tachometer, which allows RPM to be monitored to detect obstruction.

AERODYNAMIC SHAPE

A curved inlet redirects air into the shield and funnels it past the sensing area, which allows for a lower power requirement than other fan-aspirated shields on the market. The Apogee EE08-SS is a customized version of the EE08 probe made by Austrian manufacturer E + E Elektronik. After years of evaluation, the EE08-SS has emerged as our sensor of choice over more expensive probes for accuracy, stability, and durability. The Apogee EE08-SS features an improved right angle, IP67 rated, stainless-steel M12 connector; heat-reflective white cabling; and a more durable, metal-grid dust filter. These features added by Apogee only slightly increase the price over the base model from E + E, but greatly improve the performance and reduce the maintenance of the probe, especially when used with a fan-aspirated radiation shield in the Apogee TS-220-SS package.